

WARNING!

- Improper use of a Head-Edger can cause serious or fatal injury.
- Always operate with all screws in unit.
- Never operate without eye protection.
- Always wear protective clothing.
- Never operate in sandals or bare feet.
- Never operate without a factory guard or deflector in place.
- Keep bystanders at least 50 feet away at all times.
- Always shut off engine for any service.
- Always keep hands, feet and clothing away from Head-Edger while engine is running.
- Always inspect area for hidden objects that can be picked up and thrown.
- Do not use the Head-Edger to clean cracked or damaged sprinkler heads.
- Use only Head-Edger replacement blades.
- Read and understand all operating instructions and warnings furnished with the Head-Edger.

LIMITED LIFE TIME WARRANTY

WHAT IS COVERED: All parts proven to be defective in materials or workmanship after manufacturers inspection.

WHAT WE WILL DO: Replace or repair any part proven to be defective in materials or workmanship after manufacturers inspection.

WHAT IS NOT COVERED: Misuse, abuse or improper care. Threads stripped out by over-tightening. Wear items - Blades, Bearing or Boot.

WHAT PURCHASER MUST DO: Return the product, prepaid and insured to: Head Edger, Inc. with a brief description of defect. Include company name, complete address, contact and phone number. Your part will be repaired or replaced and returned to you prepaid.

Contact Head Edger, Inc. for repairs or replacement of any damaged part not covered in this limited warranty.



HEAD-EDGER, INC.

421 Highway 80 • Garden City, GA 31408

Phone (912) 964-8395

or Visit us at: www.headedger.com

Instruction Sheet

Head-Edger Patent No.: US 6,857,480 B2

Supply List

12 - 5/8" button socket cap screws

8 - 5/8" flat socket cap screws

4 - Slides - T-Bars

4 - Blades

1 - 1 1/4" Internal Retaining Ring

1 - Bearing and Boot

Tool Supplied

1 - 5/32" Short Arm Hex Key



5/8" Button Socket cap screw



5/8" flat Socket cap screw



Blade



Slide - T-Bar



Retainer Ring



Boot and Bearing

MADE IN THE USA

Important: Read all instructions before beginning.

The slides allow the blades to be adjustable.

Please read adjustment instructions before installing the slides.

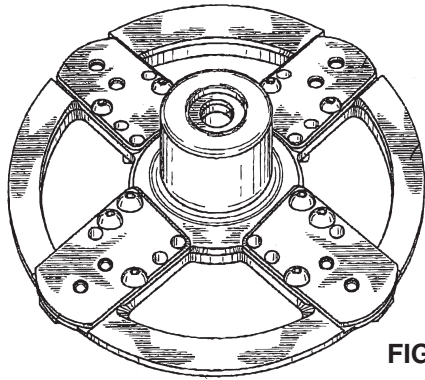

FIGURE #1

Step #1 - Install Slides to Head

Figure #1 shows slides installed with 12 (5/8") button socket cap screws.

Important:

You must have 3 screws per slide.
Hand tighten only with allen wrench.
Use of electric device could strip threads.

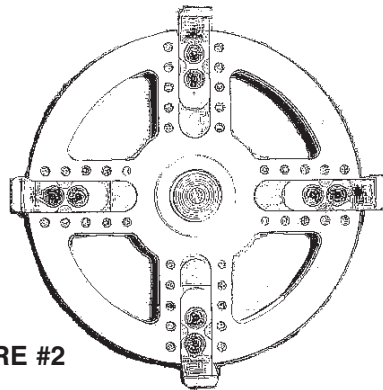

FIGURE #2

Step #2 - Install Blades to Slides

Figure #2 shows blades installed with 2 (5/8") flat socket cap screws.

Important:

Hand tighten only with allen wrench.
Use of electric device could strip threads.

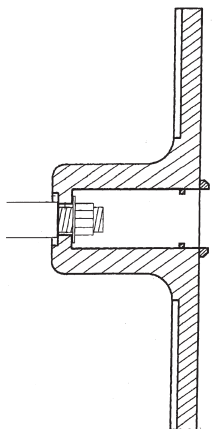

FIGURE #3

Step #3 - Install Head to Trimmer

Insert the trimmer shaft through the centered hollow shank and secure with proper locking nut (this nut would come with your trimmer unit)

Important:

Insure shaft is centered.

Step #4 - Install Boot and Bearing

Slide Bearing inside the bottom of the Head with Boot Extruding.

Install the internal retainer ring around the boot.

Lock the boot into place with the internal retainer ring using snap ring pliers.

Make sure the internal retainer ring locks in place into the groove on the head.

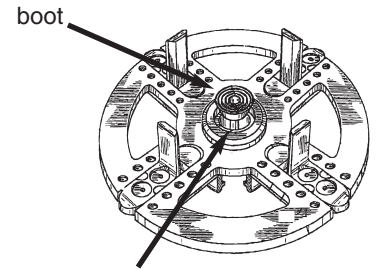

Internal Retainer Ring

ADJUSTMENT INSTRUCTIONS

With the blades in the normal or forward position:

Slide T-bars to desired position.

Three bolt holes will be in alignment.

Always secure T-bars with three bolts before operation.

Always be sure all four T-bars are adjusted to the same position.

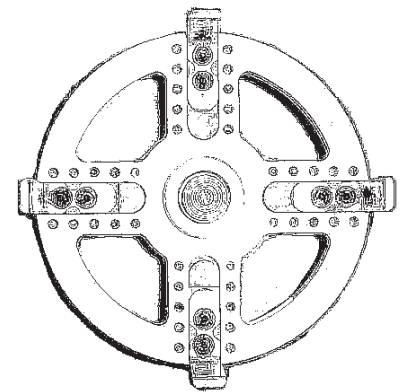

Normal Position

Slide T-bars tightly against center shaft, this is 7 3/4" adjustment. Slide T-bar outward until the next three holes are in alignment. This will be the 8" adjustment. Using the same principal, adjustments can be made: 7 3/4", 8", 8 3/4", 9", 9 3/4" and 10". To insure proper adjustment you can use a ruler or tape measure to check dimensions between blades opposite one another.

With the blades inverted or facing inward:

Slide T-bars to desired position.

Three bolt holes will be in alignment.

Always secure T-bars with three bolts before operation.

Always be sure all four T-bars are adjusted to the same position.

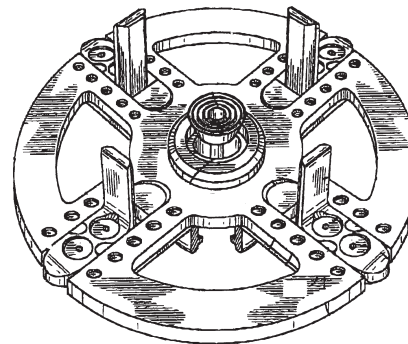

Inverted Position

Slide T-bars tightly against center shaft, this is 4 1/2" adjustment. Using the same principal as stated above, adjustments can be made: 4 1/2", 4 3/4", 5 1/2", 5 3/4" 6 1/2", and 6 3/4".